

# MIA-COM Mineralisation and De-Acidification

RWO  VEOLIA



Post-treatment of desalinated water from evaporators or reverse osmosis units such as the SRO-COM is absolutely necessary to get safe, potable water. The mineralisation and deacidification processes inside the MIA-COM unit help to prevent corrosion and improves health protection due to higher quality drinking water. The application of the mineralising unit has advantages for both crew and passengers. It protects the material of downstream equipment, for example: distribution, storage and consumers like air-conditioners, ice makers, heating systems etc.

## Your key benefits

- > Higher quality of potable water, better taste, no odour
- > Dissolving of poisonous heavy metals from the pipe surface is prevented
- > Ship equipment protected against corrosion and subsequent damages
- > Plug-and-play unit in a compact, marine-suitable design
- > Designed for start-and-forget operation
- > No external electrical power supply needed

**WATER TECHNOLOGIES**

# Mineralisation and De-Acidification

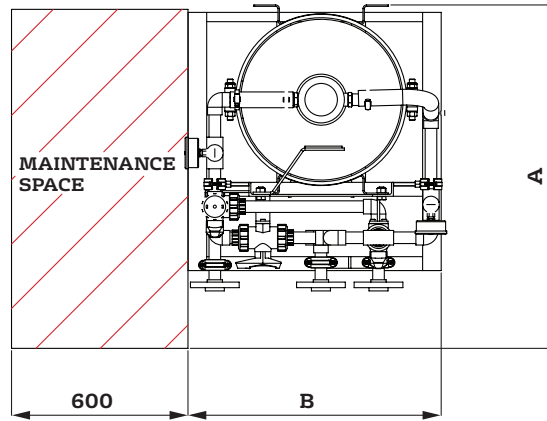
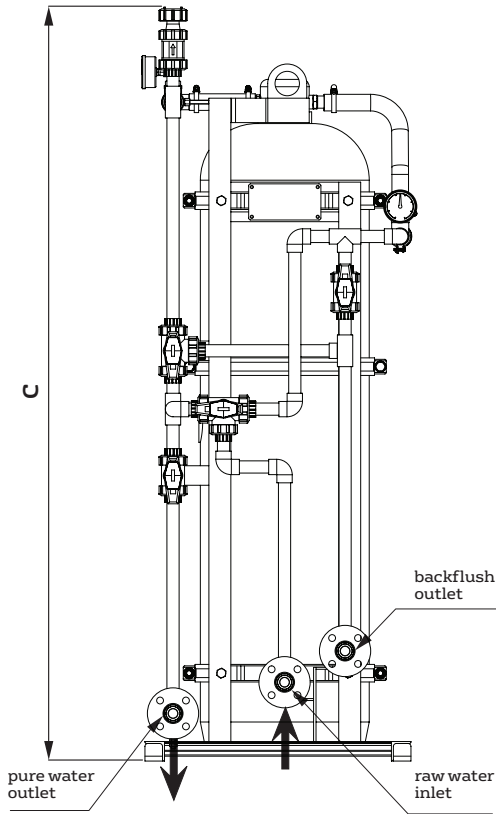

The standard capacities of the RWO mineralising units range from 0.65 m<sup>3</sup>/h to 8.50 m<sup>3</sup>/h as single filters. Mineralising units in duplex configuration, with two single filters operating in parallel mode, are also available.

## Technical Data

Type	Capacity (m <sup>3</sup> /h)	A [mm]	B [mm]	C [mm]	DN/PN	Wet Weight [kg]
MIA-COM 650	0.65	725	470	1,150	10/16	60
MIA-COM 1000	1.00	790	560	1,360	15/16	100
MIA-COM 2000	2.00	920	555	1,550	20/16	170
MIA-COM 4200	4.20	965	615	1,875	25/16	310
MIA-COM 8500	8.50	1,340	835	2,125	40/16	680

